

# Biogas Dehumidification System

## Skid-Mounted Packages for Biogas and Landfill Gas Cooling Applications



Biogas, originating from biomass, sewage plants and landfill sites is gaining increasing worldwide importance as a recognised renewable energy source. Generally, biogas is saturated with water vapour and contains other impurities which, when used as fuel, must be removed to prevent corrosion and damage to equipment and systems and improve cogeneration unit efficiency.

Biogas is primarily composed of methane and carbon dioxide with smaller amounts of hydrogen sulphide and ammonia. Trace amounts of other gases like hydrogen, nitrogen or carbon monoxide are also present in the biogas.

**The selection of effective biogas treatment equipment is therefore particularly important, both in optimising the cogeneration of electrical and thermal energy, making the most of the available renewable energy, and reducing energy consumption and operating costs to a minimum.**

Parker's solution is to dry the gas, firstly by cooling using a water-cooled heat exchanger working with an air-cooled water chiller and secondly, by removing the condensed water with a cyclonic water separator. The cooled gas can then be reheated to reduce the relative humidity and thus meet the technical demands of gas engines, turbines and other downstream equipment such as the Parker PpTek Siloxane Removal System and Biogas Upgrading System components



### Product Description

- The Parker Biogas Dehumidification System is a compact, robust and easy to handle plug & play gas conditioning package ensuring significant cost savings in investment, management and operation.
- Available in a wide range of sizes from 50 Nm<sup>3</sup>/h to 1500 Nm<sup>3</sup>/h, the Parker system has performances and flow rates aligned with typical biogas plant designs and CHP capacities.
- All gas-side components are constructed from stainless steel (AISI304 or AISI316L) with additional pickling and passivation treatment in order to ensure highly reliable and continuous operation even in the harshest site conditions.
- Designed using thermodynamic and fluid dynamic principles to ensure a high efficiency heat exchange and separation whilst maintaining low pressure drop.
- Flexibility to use a wide range of cooler/chiller combinations ensures the closest match to customer requirements thus delivering constant dewpoint performance regardless of fluctuations in operating conditions.

# Biogas Dehumidification System

The standard Biogas Dehumidification System cools biogas to a user defined dew point, using a Hypercool BioEnergy heat exchanger working with Hyperchill BioEnergy chiller and removing the condensed water with the Hypersep BioEnergy separator. Insulation, Hyperfilter BioEnergy and

Hyperdrain BioEnergy can be provided as options. This configuration is designed for installations where a blower is installed downstream of the dehumidification system, taking advantage of its position to increase the temperature of the biogas and thus decrease its relative humidity.

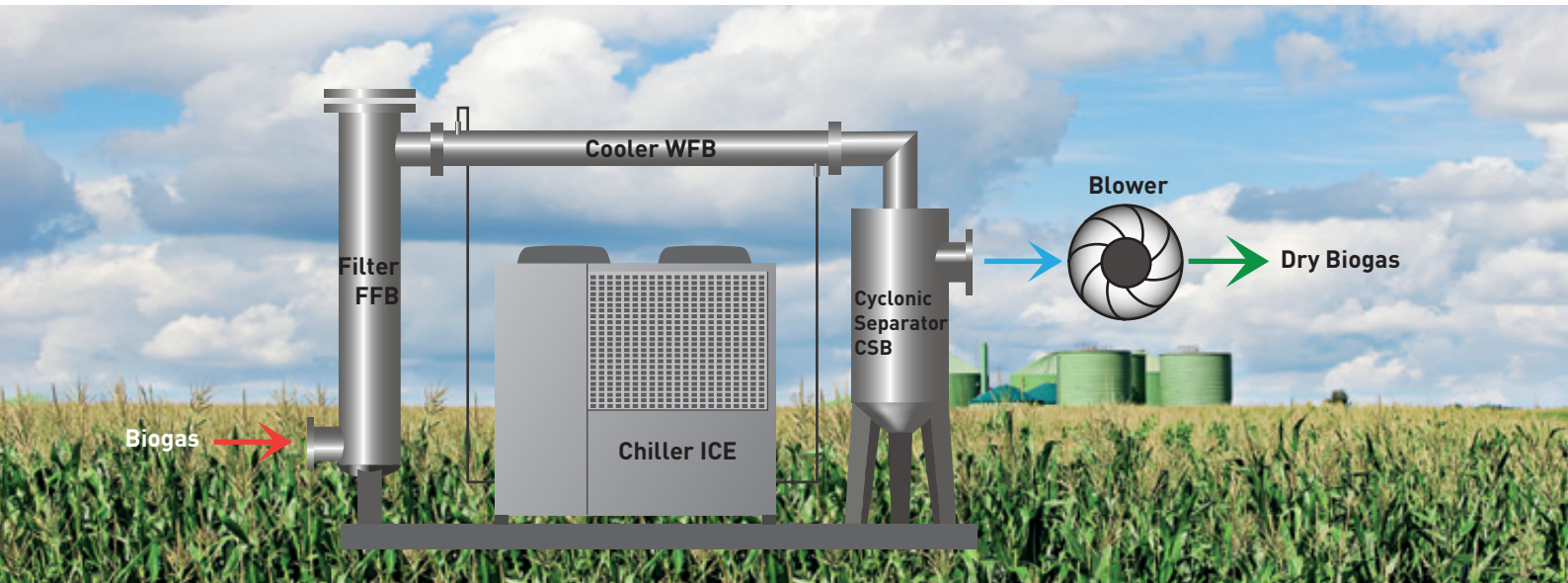

Biogas Dehumidification System									
Model	Biogas Flow Rate (m <sup>3</sup> /h)	Gas inlet * connections	Gas outlet connections	Condensate removed (kg/h)	A (mm)	B (mm)	C (mm)	D* (mm)	Weight* (kg)
skd60-007	60	DN80	DN50	3,1	2500	1700	1615	1640	558
skd105-010	105	DN80	DN50	5,3	2500	1700	1615	1640	638
skd165-014	165	DN125	DN80	8,4	2500	1700	1615	1635	690
skd265-024	265	DN125	DN80	13,5	2500	1700	1615	1635	795
skd240-030	240	DN125	DN80	12,8	3300	1800	1594	1695	880
skd360-040	360	DN200	DN125	19,2	3300	1800	1562	1975	941
skd510-060	510	DN200	DN125	27,2	3300	1800	1579	1975	1166
skd720-076	720	DN200	DN125	38,4	3350	2200	2214	1995	1451
skd1110-116	1110	DN300	DN200	59,2	3350	2200	2214	2102	1732
skd1620-116	1350	DN300	DN200	71,6	3350	2200	2214	2102	1788

Performances refer to operation with clean cooler and separator, gas flow rate at 20 °C/1 bar<sub>g</sub>. Nominal working conditions: 60 % CH<sub>4</sub>, 40 % CO<sub>2</sub>, gas inlet temperature 40 °C saturated, refrigerant inlet water temperature 1 °C, ambient temperature 35 °C, gas outlet temperature at nominal conditions 8 °C (from model skd60-007 to model skd265-024) and 4 °C (from model skd240-030 to model skd1620-116). Average pressure drop without filter 11 mbar +/-2 for all models, average pressure drops with filter 14 mbar +/- 2 for all models.

\*Data refer to skid without filter.

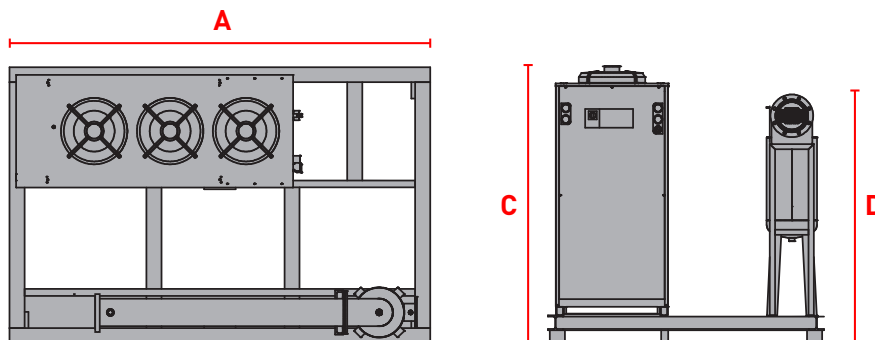

# Biogas Dehumidification System

## with 'Gas2Gas' Recuperator

The Biogas Dehumidification System with 'Gas2Gas' Recuperator BioEnergy cools biogas to a user-defined dew point and reheats the gas to a relative humidity lower than 50%. Insulation, Hyperfilter BioEnergy and Hyperdrain BioEnergy can be provided as options.

This configuration is designed for installations where a blower is installed upstream of the Dehumidification System with the 'Gas2Gas' Recuperator providing free-cooling to save energy and free-heating to reduce the relative humidity of the biogas - without the need for auxiliary heating.

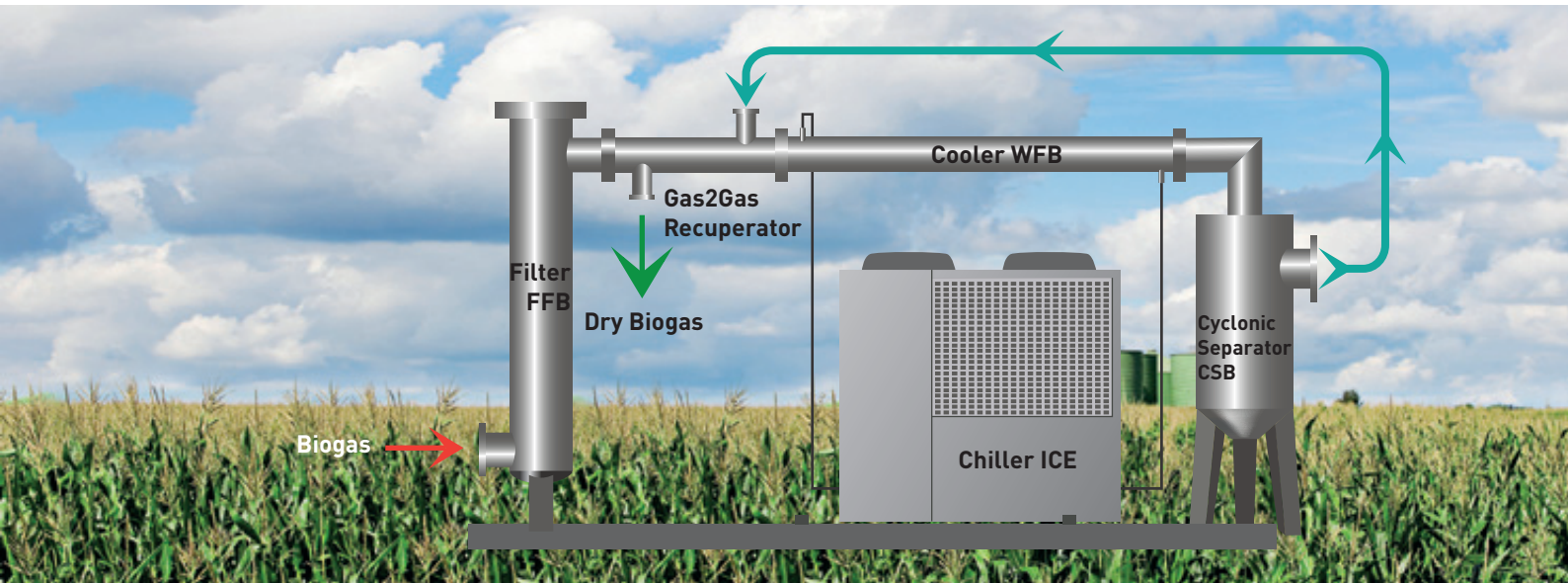

Biogas Dehumidification System with 'Gas2Gas' Recuperator									
Model	Biogas Flow Rate (m <sup>3</sup> /h)	Gas inlet * connections	Gas outlet connections	Condensate removed (kg/h)	A (mm)	B (mm)	C (mm)	D* (mm)	Weight* (kg)
skd60-007-R	60	DN80	DN40	3,1	3750	1700	1615	1982	703
skd105-010-R	105	DN80	DN40	5,4	3750	1700	1625	1982	711
skd165-014-R	165	DN125	DN50	8,5	3750	1700	1615	2040	772
skd265-024-R	265	DN125	DN50	13,5	3750	1700	1615	2040	785
skd240-030-R	240	DN125	DN50	12,8	4900	1800	1594	2100	1089
skd360-040-R	360	DN200	DN100	19,3	4900	1800	1562	2567	1264
skd510-060-R	510	DN200	DN100	27,3	4900	1800	1580	2567	1391
skd720-076-R	720	DN200	DN100	38,5	5382	2200	2214	2587	1887
skd1110-116-R	1110	DN350	DN150	59,4	5382	2200	2214	2878	2394
skd1620-116-R	1350	DN350	DN150	68,5	5382	2200	2214	2878	2450

Performances refer to operation with clean cooler and separator, gas flow rate at 20 °C/1 bar<sub>g</sub>. Nominal working conditions: 55 % CH<sub>4</sub>, 45 % CO<sub>2</sub>, gas inlet temperature 50 °C (40 °C saturated), gas inlet pressure 75 mbar<sub>g</sub>, refrigerant inlet water temperature 1 °C, ambient temperature 35 °C, gas dew point at nominal conditions 8 °C (from model skd60-007 to model skd265-024) and 4 °C (from model skd240-030 to model skd1620-116), gas outlet relative humidity below 50 %.

\*Data refer to skid without filter.

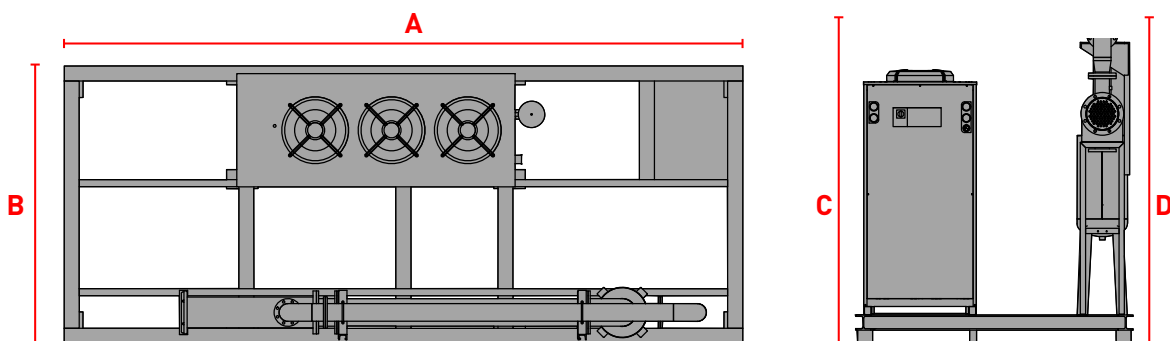



## The Key Components of the Parker Biogas Dehumidification System

Installed on a hot-galvanized steel frame, the water-chiller (Hyperchill BioEnergy), cooler (Hypercool BioEnergy) and centrifugal separator (Hypersep BioEnergy) are the key components of the Biogas Dehumidification System: they have

been specifically designed for biogas applications and provide safe and reliable operation in the harsh environments typically found at AD and Landfill biogas production sites. Furthermore, the standard biogas

dehumidification package includes water connections between Hyperchill and Hypercool, water isolating valves, water expansion tank, and counterflanges kit with gaskets for easier connection of the system to the customer pipes.

### Hyperchill BioEnergy (ICE series)

- Chiller Output 5 – 360 kW
- Special coating for corrosive environment
- Pump & tank installed in casing
- Microprocessor controlled
- Ambient range -20 °C to +45 °C
- Compliant scroll refrigerant compressor
- IP54 protection as standard



### Hypercool BioEnergy (WFB Series)

- High cooling efficiency with low pressure drop design
- Material: Parts in contact with biogas in AISI304 or AISI316L, parts not in contact with biogas in AISI304
- Max. working pressure: 0,5 bar



### Hypersep BioEnergy (CSB Series)

- Cyclonic separator optimized for biogas applications
- High separation efficiency with very low pressure drop
- Material: Parts in contact with biogas in AISI304 or AISI316L
- Max. working pressure: 0,5 bar<sub>g</sub>



## Optional Additions to Standard Skid Package

The standard Biogas Dehumidification System can be extended to include additional components such as a particulate filter, condensate drain and/or energy-saving, 'Gas2Gas' recuperator.

### Hyperfilter BioEnergy (FFB)

- Particle removal size 5 or 20 µm
- Filtration Efficiency 99,999 %
- Differential pressure 2 mbar
- Material: AISI304 or AISI316L, with additional pickling and passivation treatment
- Max. working pressure: 0,5 bar<sub>g</sub>



### Gas2Gas Recuperator BioEnergy (RBB)

- Free-cools incoming biogas to reduce chiller cooling load
- Free-heats outgoing biogas to reduce relative humidity thus eliminating the need for auxiliary heating
- High thermal transfer efficiency with very low pressure drop
- Material: AISI304 or AISI316L, with additional pickling and passivation treatment



### Hyperdrain BioEnergy (HDF220BE)

- Designed to work with dirty condensate and for low pressure operation
- No electrical wiring
- No gas loss
- Parts in contact with condensate in stainless steel and reinforced polyamide, body treated with special Hiroshield treatment for optimal operation in harsh environments



EMEA Product Information Centre

Free phone: 00 800 27 27 5374

(from AT, BE, CH, CZ, DE, DK, EE, ES, FI, FR, IE, IL, IS, IT, LU, MT, NL, NO, PL, PT, RU, SE, SK, UK, ZA)

US Product Information Centre

Toll-free number: 1-800-27 27 537

[www.parker.com/gsf](http://www.parker.com/gsf)